

INSTATRIKE

BY



Installation Manual

1800cc Honda Goldwing

Limited Warranty

TOW-PAC, INC. warrants to the first end user purchaser that this product "InstaTrike" when purchased will be free from defective workmanship and materials, and agrees that it will, at its option, either repair the defect or replace the defective Product for the period of one year from date of original purchase.

This warranty does not apply to tires or to the appearance of any item which has been damaged, defaced, been subjected to misuse, or which has been altered or modified in design or construction.

Neither the sales personnel of the seller nor any other person is authorized to make any warranties other than those described above or to extend the duration of any warranties beyond the time period described above on behalf of TOW-PAC, INC.

NOTICE OF LIMITED LIABILITY

Tow-Pac, Inc. warrants *only* components supplied by Tow-Pac, Inc. Tow-Pac, Inc. cannot be responsible for any components on owners motorcycle including frames, hardware, aftermarket accessories, etc. Owner is solely responsible for ensuring motorcycle is in sound mechanical order. Tow-Pac, Inc cannot be responsible for any damage due to improper installation of Tow-Pac components or use of any hardware (bolts, nuts, etc) on Tow-Pac components not supplied directly by Tow-Pac, Inc. Owner is solely responsible for installation of Tow-Pac components. Please refer to limited warranty for warranty details.

Notice

After your InstaTrike is installed, take some time to get used to “Trike” handling characteristics.

- On a Trike you will **steer** rather than **lean** as you would on a conventional two wheel motorcycle.
- Take corners **very slowly** until you get used to the feel of cornering on a Trike.
- Remember to use your front brake in tandem with your rear brake. This will greatly increase your stopping power when in Trike configuration.
- With InstaTrike installed remember the outrigger wheels. Use caution not to run them into objects.
- Keep your feet up at all times.

Important Notices

- Remove all preload from rear suspension of motorcycle after initial installation of InstaTrike. Readjust preload as needed.
- InstaTrike is designed for use on paved surfaces *only*. Use of InstaTrike on unpaved terrain may void warranty.
- Installation of InstaTrike requires your motorcycle to be level. Some motorcycles are not level when on the center stand. Level the motorcycle by placing spacers under the center stand as needed
- ***When installing trailer hitch attach all bolts and brackets loosely. After all bolts and brackets are in place tighten all bolts.***
- Using the enclosed wooden risers under each InstaTrike wheel may make installation and removal easier particularly if traction kit is installed.

Installation Checklist

- Review entire installation manual**
- Remove saddle bags and rear fender cover**
- Modify rear fender cover**
- Install receiver hitch and double check all bolts**
- Remount saddle bags**
- Assemble InstaTrike hitch cart**
- Attach InstaTrike to motorcycle via receiver hitch**
- Attach leanstop brace bolts to receiver hitch**
- Align InstaTrike wheels**
- Double check all bolts for tightness**
- Test ride InstaTrike slowly in an open area to familiarize yourself with handling characteristics**

Receiver Hitch Installation

Attach all bolts and brackets loosely until all are in place. Tighten only after all components are in place.

- 1) Place motorcycle on center stand
- 2) Remove side covers
- 3) Loosen and move saddle bags to the side.
(On 1800 Goldwing, seat must be removed in order to loosen and move saddle bags.) (Use care to secure loosened saddle bags)
- 4) Remove rear fender cover
- 5) Attach brackets **C** (left) / **D** (right) to top rear crossbar with U-bolts provided. Brackets attach to outside of plastic rear inner fender tabs. U-Bolts clamp around crossbar with threaded ends pointing toward rear of motorcycle.

NOTE: *When U-Bolts are tightened after hitch installation is complete, remove any excess thread extending past the locknut with a saw or cutters.*

- 6) With brackets A and B attached to top of forward hitch arms, slide hitch into place from the rear and loosely attach brackets A and B to bottom of rear crashbars with U-bolts provided.
Check motorcycle's rear crashbar attachment bolts for tightness.

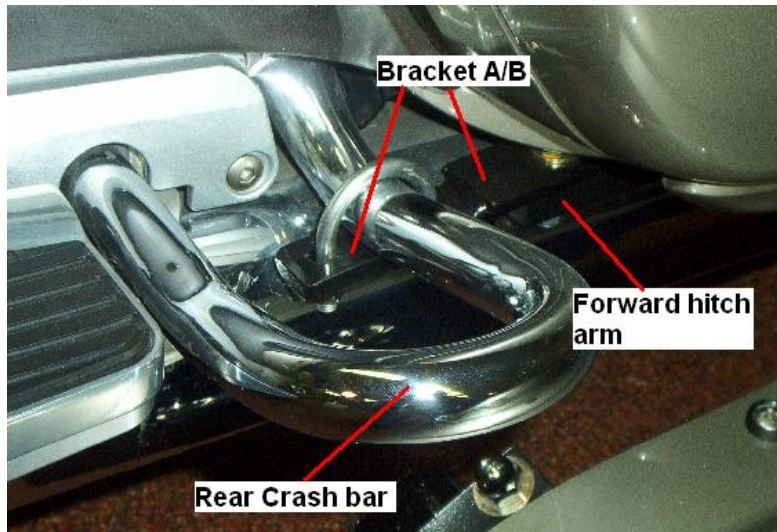

NOTICE: Check crashbar bolts for tightness
Caution: Do not over tighten U-Bolts and crush crashbar

- 7) Attach bottom of **C/D** to top of rear hitch bar.
- 8) Attach rear hitch bar to motorcycle sub frame with U-bolts provided.
Caution: Do not over tighten U-Bolts and crush crashbar
- 9) Be sure hitch is straight and even on motorcycle. Tighten all bolts.
- 10) Remount rear fender cover and saddle bags.

Hitch Diagram

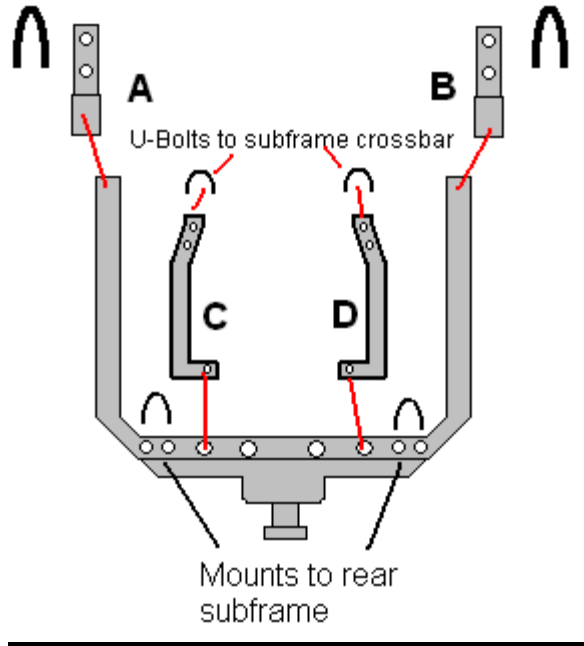

InstaTrike Assembly Diagram

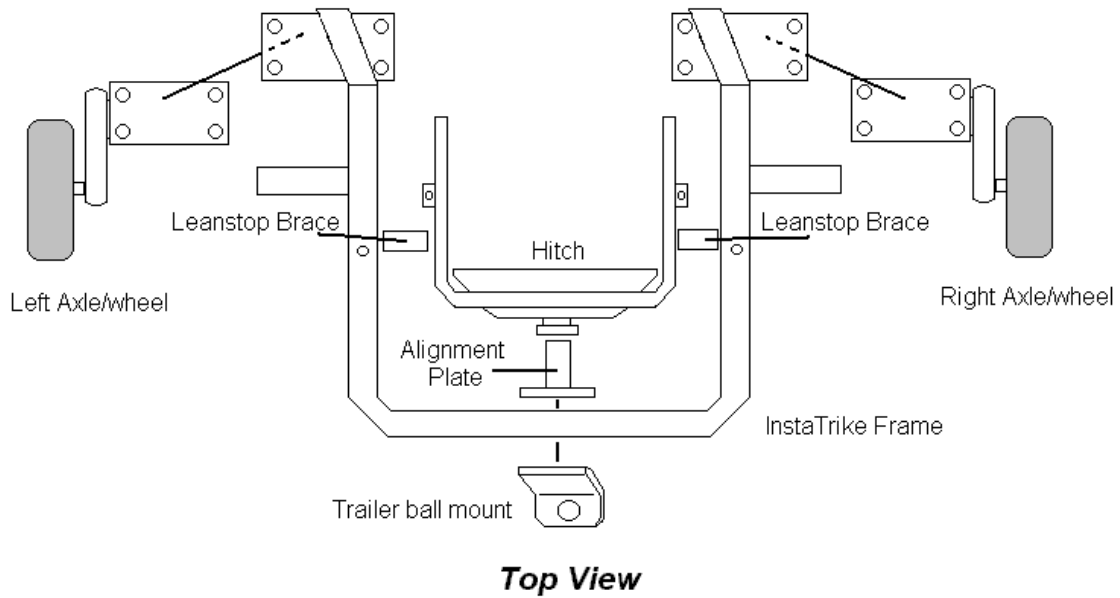

INSTALLATION OF THE TOW-PAC HITCH CART.

1. Place your motorcycle on a smooth flat surface, like a garage floor, and rest it on its center stand.
2. Assemble the axles, tires and wheels, and fenders onto the tow-pac hitch cart.
3. Carefully align the tow-pac hitch cart's hitch mount with the receiver hitch on the motorcycle. Now push the hitch mount into the receiver hitch. (this might be a little difficult until you get use to doing it. Removing the paint from the hitch mount and applying a little grease will help.)
4. Place the hitch pin through the receiver hitch and hitch mount (*alignment plate*). Install and tighten the tension bolt.
5. Push the motorcycle off of the center stand and risers if used.
6. Bolt leanstop braces to hitch. (Bolt inserts from the bottom) Be certain to replace washers/spacers in the same configuration as when you removed them. *see diagram next page*
7. Check all bolts for tightness.
8. You are now ready for the test ride.
 - A. Keep your feet up!
 - B. Ride slowly in first gear until you are comfortable with the Tow-Pac system.

Leanstop Braces

- When installing InstaTrike, bolt leanstop brace to receiver hitch by inserting bolt from *bottom* through the leanstop brace and washers/spacers. Thread bolt into bracket on hitch and tighten.
- When removing InstaTrike reverse the above procedure.
- Adding or removing washers/spacers between receiver hitch and leanstop brace will allow you to level your motorcycle if necessary.
- Removing washers/spacers between receiver hitch and leanstop brace will allow for more traction on motorcycle rear wheel.

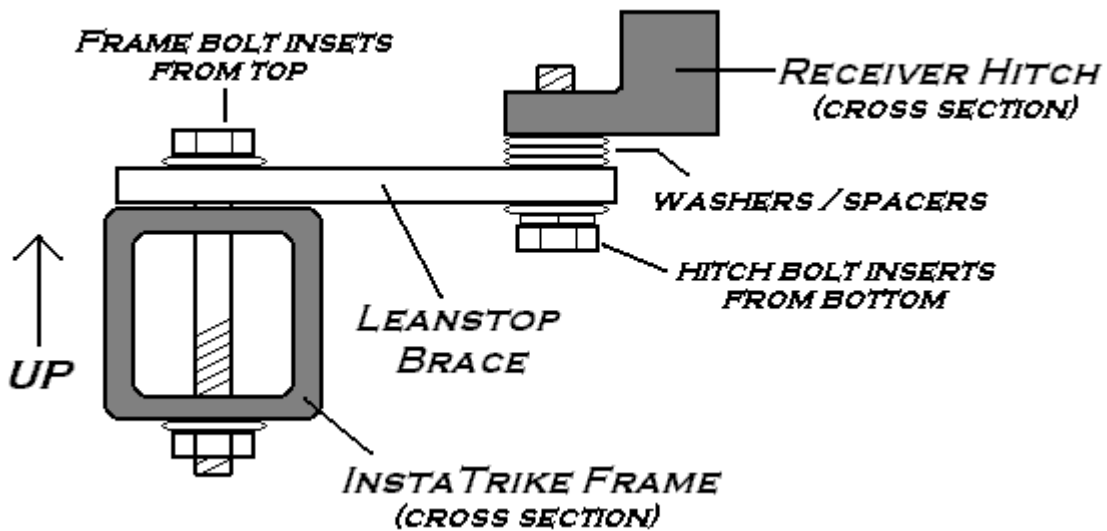

Leanstop brace is slotted to allow for proper alignment with bolt holes

Wheel Height / Traction Adjuster

The wheel height/traction adjuster (right and left side) allows you to selectively adjust the position of your trike wheels in order to customize ride, handling, level,

and traction characteristics. Your trike is shipped with the adjuster preset to an optimum position for your model of motorcycle however you can make whatever adjustments necessary to customize to your bike and personal preference.

Shortening the adjuster arm **raises** the trike wheels and places more of the weight of your motorcycle on the motorcycle wheel. This increases motorcycle traction and gives a generally softer ride.

- 1) Loosen jam nuts
- 2) Shorten adjuster arm by turning adjuster nut **A** toward bolt **C** desired amount.
- 3) Turn adjuster nut **B** until it tightens against adjuster bracket and adjuster nut **A**
- 4) Tighten nuts **A** and **B** and jam nuts

Lengthening the adjuster arm **lowers** the trike wheels and places more of the weight of your motorcycle on the trike wheels. This gives a firmer ride and increases handling/cornering.

- 1) Loosen jam nuts
- 2) Lengthen adjuster arm by turning adjuster nut **B** toward bolt **D** desired amount.
- 3) Turn adjuster nut **A** until it tightens against adjuster bracket and adjuster nut **B**
- 4) Tighten nuts **A** and **B** and jam nuts

If necessary the pivot bolt and bolts C and D and be loosened for adjustment
Be certain to retighten all bolts after adjustment.

NOTICE: Check all bolts and nuts periodically for tightness
NOTICE: Be sure motorcycle is level after adjustment.

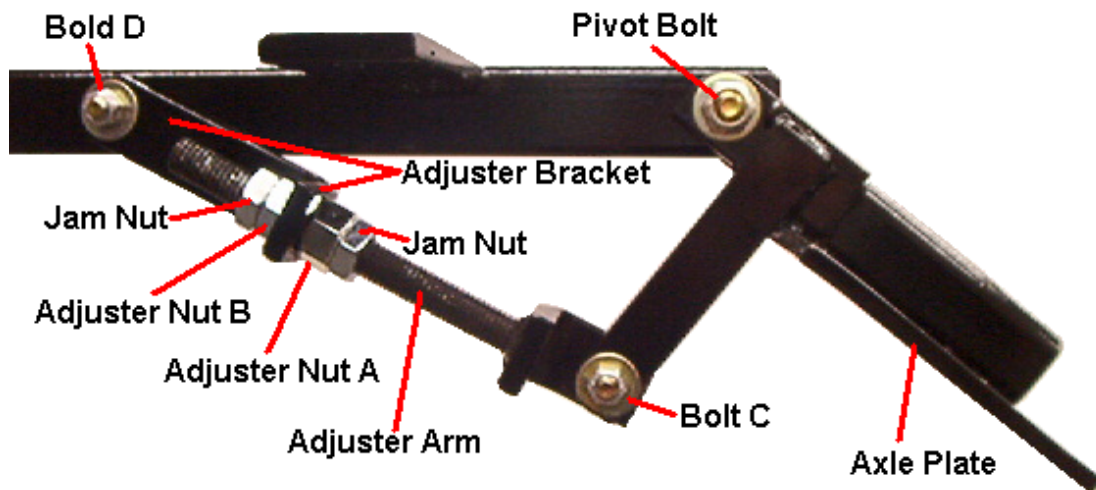

Wheel Alignment

Wheel alignment is critical for proper tire wear and handling.

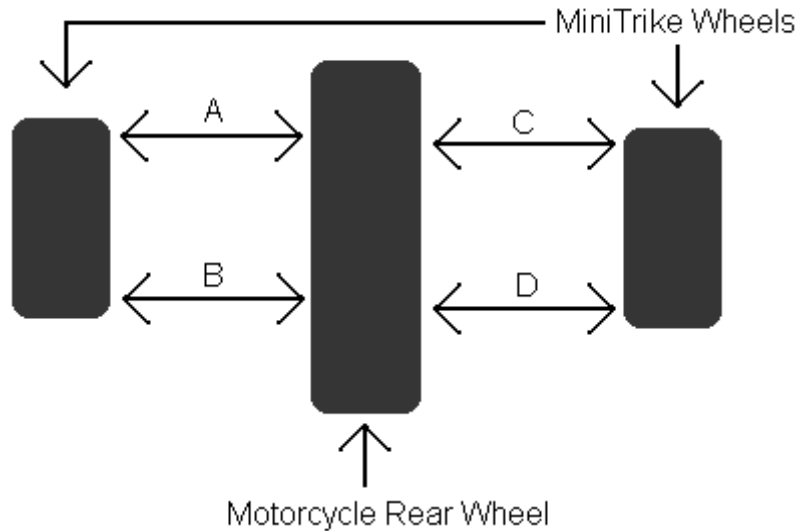

Top View

With InstaTrike installed and motorcycle on center stand, measure **A** and **B**. Loosen axle plates and align wheel so **A** and **B** are equal to within 1/16th of an inch. Tighten axle bolts and torque to 45 pounds. Repeat for **C** and **D**. It may be necessary to shim axle plates for proper alignment.

NOTE: The measurement of **A** and **B** may not be the same as **C** and **D**. This is normal and presents no difficulty.

IMPORTANT NOTICE

Periodically check leanstop bolts for tightness. Use enclosed jam nuts on top of bolt to further secure leanstop bolt.

